

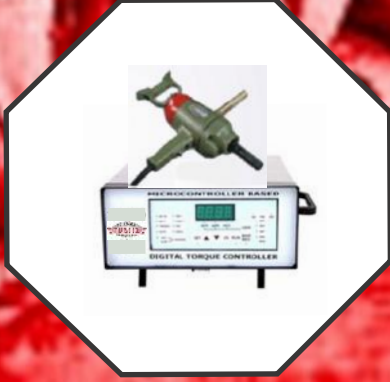

TUBEEX ENGINEERING



E-mail : sales@tubeexengg.com
Customer care : +91-7718077764



www.tubeexengg.com

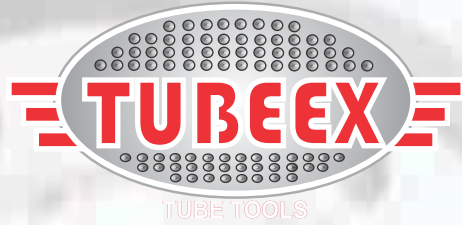

CONDENSER / HEAT EXCHANGER TUBE EXPANDERS



1/4" - 3/8"
O.D.

AN SERIES

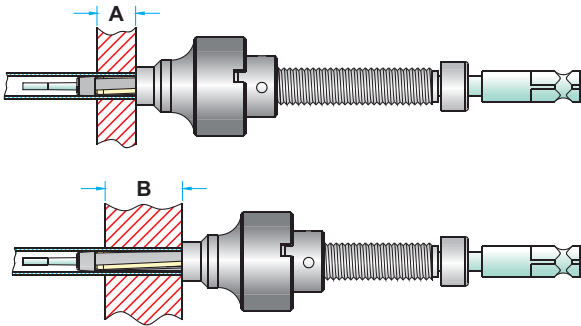

FOR TUBES INTERNAL DIAMETER
FROM (3.8 mm) .152" TO (8.4 mm) .331"

TUBE EXPANDER FITTED WITH ROLLER LENGTH	FOR TUBE SHEET ADJUSTABLE RANGE	
	MINIMUM A	MAXIMUM B
(25.4mm) 1"	(6.35mm) 1/4"	(25.4mm) 1"

- Use : Oil Coolers, Radiators and other apparatus with small diameter tubes.
- Advantages Captive mandrel eliminates nut on mandrel tip which prevents scratching of tube I.D.
- Increased feed angle makes it the fastest operating tool on the market, ideal for high production environments.

Tube O.D. (mm) inch	Tube Thickness			Tube I.D.		Minimum I.D. Tool Enters		Maximum Expansion of Tool		EXPANDER with (25.4 mm) 1" Long Rollers		
	bwg	mm	inch	mm	inch	mm	inch	mm	inch	Complete Tool No.	Mandrel No.	Rollers Set. No.
6.35 1/4	18	1.24	.049	3.8	.152	3.7	.148	4.2	.167	A-25018	M-21819	R-20018
	19	1.06	.042	4.2	.166	4.0	.160	4.5	.180	A-25019	M-21819	R-21920
	20	0.88	.035	4.5	.180	4.4	.175	4.9	.196	A-25020	M-22021	R-21920
	21	0.81	.032	4.7	.186	4.5	.180	5.1	.202	A-25021	M-22021	R-22124
	22	0.71	.028	4.9	.194	4.8	.190	5.4	.213	A-25022	M-20022	R-22124
	23	0.63	.025	5.0	.200	4.9	.195	5.5	.216	A-25023	M-22324	R-21920
	24	0.55	.022	5.2	.206	5.1	.201	5.7	.224	A-25024	M-22324	R-22124
	28	0.35	.014	5.6	.222	5.4	.217	6.1	.243	A-25028	M-22830	R-22830
	29	0.33	.013	5.7	.224	5.4	.217	6.1	.243	A-25028	M-22830	R-22830
30	0.30	.012	5.7	.226	5.4	.217	6.1	.243	A-25028	M-22830	R-22830	
9.53 3/8	14	2.10	.083	5.3	.209	5.1	.204	5.8	.230	A-37514	M-22830-B	R-21920
	15	1.82	.072	5.8	.231	5.6	.225	6.6	.265	A-37515	M-22830-B	R-31516
	16	1.65	.065	6.2	.245	6.0	.238	7.0	.278	A-37516	M-31617	R-31516
	17	1.47	.058	6.5	.259	6.4	.253	7.4	.293	A-37517	M-31617	R-31720
	18	1.24	.049	7.0	.277	6.8	.270	7.8	.310	A-37518	M-30018	R-31720
	19	1.06	.042	7.3	.291	7.1	.285	8.1	.325	A-37519	M-30019	R-31720
	20	0.88	.035	7.7	.305	7.4	.295	8.4	.335	A-37520	M-32021	R-31720
	21	0.81	.032	7.9	.311	7.5	.305	8.6	.345	A-37521	M-32021	R-32122
	22	0.71	.028	8.1	.319	7.9	.312	8.9	.353	A-37522	M-32224	R-32122
23	0.63	.025	8.2	.325	8.1	.318	9.2	.363	A-37523	M-32224	R-32324	
24	0.55	.022	8.4	.331	8.1	.318	9.2	.363	A-37523	M-32224	R-32324	

Note : All 'AN' series expanders come with 1/4" square mandrel drives. Round mandrel drives are optional.

900 SERIES

1/4" - 3/8"
O.D.

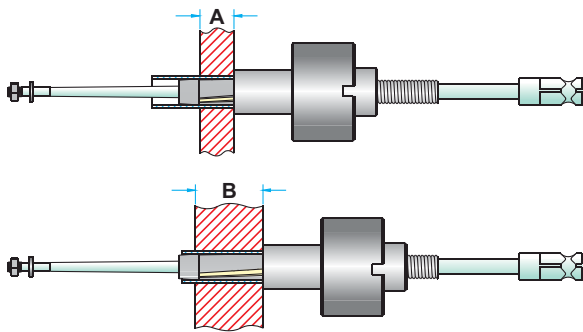

FOR TUBES INTERNAL DIAMETER
FROM (3.8 mm) .152" TO (8.4 mm) .331"

TUBE EXPANDERS FITTED WITH ROLLER LENGTH	FOR TUBE SHEET ADJUSTABLE RANGE	
	MINIMUM A	MAXIMUM B
(19.05mm)	(6.35mm) 1/4"	(19.05mm) 3/4"
(31.75mm) 1.1/4"	(19.05mm) 3/4"	(31.75mm) 1.1/4"

- Use : Oil Coolers, Radiators and other apparatus with small diameter tubes.
- This tool has been the workhorse for several years for use on small diameter tubes.

Tube O.D. (mm) inch	Tube Thickness			Tube I.D.		Minimum I.D. Tool Enters		Maximum Expansion of Tool		EXPANDER with (19.05 mm) 3/4" Long Rollers			EXPANDER with (31.75 mm) 1.1/4" Long Rollers		
	bwg	mm	inch	mm	inch	mm	inch	mm	inch	Complete Tool No.	Mandrel No.	Rollers Set. No.	Complete Tool No.	Mandrel No.	Rollers Set. No.
(6.35) 1/4	20	0.88	.035	4.5	.180	4.4	.175	5.1	.200	923	M-40	923	-	-	-
	21	0.81	.032	4.7	.186	4.5	.180	5.2	.207	924	M-40	924	-	-	-
	22	0.71	.028	4.9	.194	4.8	.190	5.5	.216	925	M-41	925	-	-	-
	23	0.63	.025	5.0	.200	4.9	.195	5.6	.222	926	M-41	923	-	-	-
	24	0.55	.022	5.2	.206	5.1	.201	5.8	.230	927	M-41	924	-	-	-
	28	0.35	.014	5.6	.222	5.6	.222	6.0	.238	928	928	903	-	-	-
	29	0.33	.013	5.7	.224	5.6	.222	6.0	.238	928	928	903	-	-	-
	30	0.30	.012	5.7	.226	5.6	.222	6.0	.238	928	928	903	-	-	-
(9.53) 3/8	14	2.10	.083	5.3	.209	5.1	.201	5.8	.232	927	M-41	924	-	-	-
	15	1.82	.072	5.8	.231	5.8	.230	6.7	.265	915	M-42	903	-	-	-
	16	1.65	.065	6.2	.245	6.1	.240	6.9	.275	916	M-36	916L	916	M-36L	916
	17	1.47	.058	6.5	.259	6.4	.255	7.3	.289	918	M-38	903	920	M-38	904
	18	1.24	.049	7.0	.277	6.9	.272	7.8	.307	901	M-30	903	902	M-30	904
	19	1.06	.042	7.3	.291	7.2	.286	8.1	.320	903	M-31	903	904	M-31	904
	20	0.88	.035	7.7	.305	7.6	.300	8.4	.334	905	M-32	907	906	M-32	908
	21	0.81	.032	7.9	.311	7.7	.306	8.6	.340	907	M-33	907	908	M-33	908
	22	0.71	.028	8.1	.319	7.9	.314	8.8	.349	909	M-34	909	910	M-34	910
	23	0.63	.025	8.2	.325	8.1	.320	9.0	.357	911	M-34	911	912	M-34	912
	24	0.55	.022	8.4	.331	8.1	.320	9.0	.357	911	M-34	911	912	M-34	912

Note : All '900' series expanders come with 1/4" square mandrel drives. Round mandrel drives are optional.

3/8" O.D.

1300 SERIES

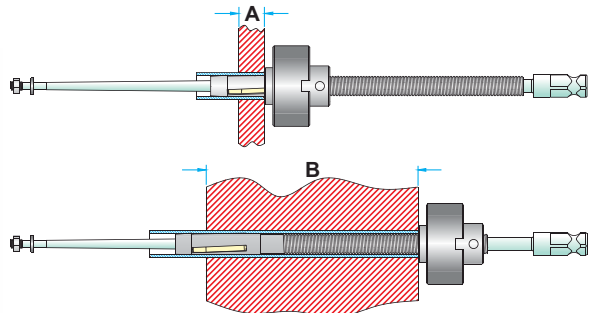

FORTUBES INTERNAL DIAMETER FROM (5.8 mm) .231" TO (8.4 mm) .331"

TUBE EXPANDERS FITTED WITH ROLLER LENGTH	FOR TUBE SHEET ADJUSTABLE RANGE	
	MINIMUM A	MAXIMUM B
(19.05mm) 3/4"	(6.35mm) 1/4"	(19.5mm) 3/4"
(31.75mm) 1.1/4"	(19.05mm) 3/4"	(31.75mm) 1.1/4"

• Use : Oil Coolers, Radiators and other apparatus with small diameter tubes and thick tube sheets.

Tube O.D. (mm) inch	Tube Thickness		Tube I.D.		Minimum I.D. Tool Enters		Maximum Expansion of Tool		EXPANDER with (19.05 mm) 3/4" Long Rollers			EXPANDER with (31.75 mm) 1.1/4" Long Rollers			
	bwg	mm	inch	mm	inch	mm	inch	mm	inch	Complete Tool No.	Mandrel No.	Rollers Set. No.	Complete Tool No.	Mandrel No.	Rollers Set. No.
3/8 (9.53)	15	1.82	.072	5.8	.231	5.8	.230	6.7	.265	1315	M-86	1315	1316	M-86	1316
	16	1.65	.065	6.2	.245	6.1	.240	6.9	.275	1319	M-86	916	1319 L	M-86	916
	17	1.47	.058	6.5	.259	6.4	.255	7.3	.289	1317	M-88	903	1318	M-88	904
	18	1.24	.049	7.0	.277	6.9	.272	7.8	.307	1301	M-80	903	1302	M-80	904
	19	1.06	.042	7.3	.291	7.2	.286	8.1	.320	1303	M-81	903	1304	M-81	904
	20	0.88	.035	7.7	.305	7.6	.300	8.4	.334	1305	M-82	907	1306	M-82	908
	21	0.81	.032	7.9	.311	7.7	.306	8.6	.340	1307	M-83	907	1308	M-83	908
	22	0.71	.028	8.1	.319	7.9	.314	8.8	.349	1309	M-84	909	1310	M-84	910
23	0.63	.025	8.2	.325	8.1	.320	9.0	.357	1311	M-84	911	1312	M-84	912	
24	0.55	.022	8.4	.331	8.1	.320	9.0	.357	1311	M-84	911	1312	M-84	912	

Note : All '1300' series expanders come with 1/4" square mandrel drives. Round mandrel drives are optional.

5/16" - 1 1/8" O.D.

AL SERIES

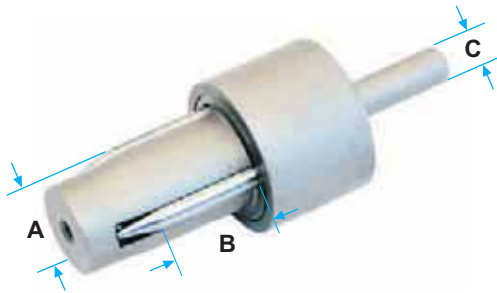

This Expander is used to enlarge the ends of soft tube so that another tube of same size can be inserted into the expanded section and soldered for a leak proof joint. These Expanders are designed to leave 0.015" clearance for slip fit and soldering. Special sizes and shanks on order. Average depth of expansion is 3/4". Specify tube gauge on order.

Tube O.D.		Expander No.	Rollers Set No.	A		B		C	
mm	inch			mm	inch	mm	inch	mm	inch
7.93	5/16	AL-312	ALR-312	8.38	0.33	15.87	5/8	6.35	1/4
9.53	3/8	AL-375	ALR-375	9.90	0.39	15.87	5/8	6.35	1/4
11.11	7/16	AL-407	ALR-407	11.43	0.45	15.87	5/8	7.93	5/16
12.70	1/2	AL-500	ALR-500	13.20	0.52	15.87	5/8	7.93	5/16
14.28	9/16	AL-562	ALR-562	14.73	0.58	19.05	3/4	7.93	5/16
15.87	5/8	AL-625	ALR-625	16.25	0.64	19.05	3/4	7.93	5/16
19.05	3/4	AL-750	ALR-750	19.55	0.77	19.05	3/4	9.52	3/8
22.22	7/8	AL-875	ALR-875	22.60	0.89	19.05	3/4	9.52	3/8
25.40	1	AL-1000	ALR-1000	25.65	1.01	25.40	1	9.52	3/8
28.57	1.1/8	AL-1125	ALR-1125	28.95	1.14	25.40	1	12.70	1/2
31.75	1.1/4	AL-1250	ALR-1250	32.25	1.27	25.40	1	12.70	1/2
34.92	1.3/8	AL-1375	ALR-1375	35.30	1.39	25.40	1	12.70	1/2
38.10	1.1/2	AL-1500	ALR-1500	38.60	1.52	25.40	1	12.70	1/2
41.27	1.5/8	AL-1625	ALR-1625	41.65	1.64	25.40	1	14.28	9/16

800 SERIES

1/2"-1 1/2"
O.D.

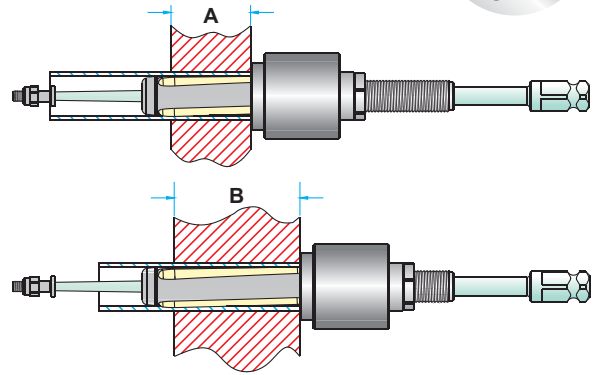

FORTUBES INTERNAL DIAMETER
FROM (8.4 mm) .334" TO (36.3 mm) 1.43"

Use : Most popular tool worldwide for use on heat exchangers and condensers with tubes of 1/2"-1.1/2" O.D.

TUBE EXPANDERS FITTED WITH ROLLER LENGTH	FOR TUBE SHEET ADJUSTABLE RANGE	
	MINIMUM A	MAXIMUM B
(38.1mm)	(12.7mm) 1/2"	(38.1mm) 1.1/2"
(57.1mm) 2.1/4"	(31.7mm) 1.1/4"	(57.1mm) 2.1/4"

Tube O.D. (mm) inch	Tube Thickness			Tube I.D.		Minimum I.D. Tool Enters		Maximum Expansion of Tool		EXPANDER with (38.10 mm) 1.1/2" Long Rollers			EXPANDER with (57.15 mm) 2.1/4" Long Rollers		
	bwg	mm	inch	mm	inch	mm	inch	mm	inch	Complete Tool No.	Mandrel No.	Rollers Set. No.	Complete Tool No.	Mandrel No.	Rollers Set. No.
(12.70) 1/2	14	2.10	.083	8.4	.334	8.2	.324	9.5	.374	797	797	797	-	-	-
	15	1.82	.072	9.0	.356	8.8	.348	10.1	.398	799	799	R-1	-	-	-
	16	1.65	.065	9.4	.370	9.1	.360	10.4	.410	801	M-1	R-1	-	-	-
	17	1.47	.058	9.7	.384	9.5	.374	10.7	.424	803	M-1	R-2	-	-	-
	18	1.24	.049	10.2	.402	9.9	.392	11.3	.447	805	M-2	R-3	-	-	-
	20	0.88	.035	10.9	.430	10.3	.406	11.7	.461	805 S	M-3	R-3	-	-	-
(15.88) 5/8	12	2.76	.109	10.3	.407	9.9	.392	11.3	.447	805	M-2	R-3	-	-	-
	13	2.41	.095	11.0	.435	10.8	.425	12.1	.480	807	M-3	R-4	-	-	-
	14	2.10	.083	11.6	.459	11.4	.449	12.9	.509	809	M-4	R-4	810	M-4	R-4-A
	15	1.82	.072	12.2	.481	11.9	.471	13.6	.536	811	M-5	R-5	812	M-5	R-5-A
	16	1.65	.065	12.5	.495	12.3	.485	13.9	.550	813	M-5	R-6	814	M-5	R-6-A
	17	1.47	.058	12.9	.509	12.6	.499	14.3	.564	815	M-6	R-6	816	M-6	R-6-A
	18	1.24	.049	13.3	.527	13.1	.517	14.5	.572	817	M-7	R-7	818	M-7	R-7-A
	19	1.06	.042	13.7	.541	13.2	.522	14.7	.582	819	M-6	R-7	820	M-6	R-7-A
	20	0.88	.035	14.1	.555	13.6	.536	15.1	.596	819 S	M-8	R-7	820 S	M-8	R-7-A
	21	0.81	.032	14.2	.561	13.6	.536	15.1	.596	819 S	M-8	R-7	820 S	M-8	R-7-A
	22	0.71	.028	14.4	.569	13.6	.536	15.1	.596	819 S	M-8	R-7	820 S	M-8	R-7-A
(19.05) 3/4	10	3.40	.134	12.2	.482	11.9	.471	13.6	.536	811	M-5	R-5	812	M-5	R-5-A
	11	3.04	.120	12.9	.510	12.6	.499	14.3	.564	815	M-6	R-6	816	M-6	R-6-A
	12	2.76	.109	13.5	.532	13.2	.522	14.7	.582	819	M-6	R-7	820	M-6	R-7-A
	13	2.41	.095	14.2	.560	13.9	.550	15.6	.615	821	M-8	R-8	822	M-8	R-8-A
	14	2.10	.083	14.8	.584	14.5	.574	16.2	.639	823	M-8	R-9	824	M-8	R-9-A
	15	1.82	.072	15.3	.606	15.1	.596	16.7	.661	825	M-8	R-10	826	M-8	R-10-A
	16	1.65	.065	15.7	.620	15.3	.605	17.4	.685	827	M-9	R-10	828	M-9	R-10-A
	17	1.47	.058	16.1	.634	15.7	.619	17.7	.699	829	M-9	R-11	830	M-9	R-11-A
	18	1.24	.049	16.5	.652	15.7	.619	17.7	.699	829	M-9	R-11	830	M-9	R-11-A
	19	1.06	.042	16.9	.666	16.3	.642	18.3	.722	831	M-9	R-12	832	M-9	R-12-A
	20	0.88	.035	17.2	.680	16.3	.642	18.3	.722	831	M-9	R-12	832	M-9	R-12-A
	21	0.81	.032	17.4	.686	16.3	.642	18.3	.722	831	M-9	R-12	832	M-9	R-12-A
	22	0.71	.028	17.6	.694	16.3	.642	18.3	.722	831	M-9	R-12	832	M-9	R-12-A
(22.22) 7/8	10	3.40	.134	15.4	.607	15.1	.596	16.7	.661	825	M-8	R-10	826	M-8	R-10-A
	11	3.04	.120	16.1	.635	15.7	.619	17.7	.699	829	M-9	R-11	830	M-9	R-11-A
	12	2.76	.109	16.6	.657	16.3	.642	18.3	.722	831	M-9	R-12	832	M-9	R-12-A
	13	2.41	.095	17.4	.685	17.0	.670	19.0	.750	833	M-10	R-13	834	M-10	R-13-A
	14	2.10	.083	18.0	.709	17.4	.685	19.6	.774	835	M-11	R-14	836	M-11	R-14-A
	15	1.82	.072	18.5	.731	18.0	.712	20.3	.801	837	M-11	R-15	838	M-11	R-15-A
	16	1.65	.065	18.9	.745	18.4	.726	20.7	.815	839	M-12	R-15	840	M-12	R-15-A
	17	1.47	.058	19.2	.759	18.8	.740	21.0	.829	843	M-12	R-16	844	M-12	R-16-A
	18	1.24	.049	19.7	.777	18.8	.740	21.0	.829	843	M-12	R-16	844	M-12	R-16-A



800 SERIES

Tube O.D. (mm) inch	Tube Thickness			Tube I.D.		Minimum I.D. Tool Enters		Maximum Expansion of Tool		EXPANDER with (38.10 mm) 1.1/2" Long Rollers			EXPANDER with (57.15 mm) 2.1/4" Long Rollers		
	bwg	mm	inch	mm	inch	mm	inch	mm	inch	Complete Tool No.	Mandrel No.	Rollers Set. No.	Complete Tool No.	Mandrel No.	Rollers Set. No.
1 (25.40)	8	4.19	.165	17.0	.670	16.6	.655	18.6	.735	841	M-9	R-13	842	M-9	R-13-A
	9	3.75	.148	17.8	.704	17.4	.685	19.6	.774	835	M-11	R-14	836	M-11	R-14-A
	10	3.40	.134	18.5	.732	18.0	.712	20.3	.801	837	M-11	R-15	838	M-11	R-15-A
	11	3.04	.120	19.3	.760	18.8	.740	21.0	.829	843	M-12	R-16	844	M-12	R-16-A
	12	2.76	.109	19.8	.782	19.3	.763	21.6	.852	845	M-12	R-17	846	M-12	R-17-A
	13	2.41	.095	20.5	.810	20.0	.791	22.3	.880	847	M-12	R-18	848	M-12	R-18-A
	14	2.10	.083	21.1	.834	20.5	.810	23.0	.909	849	M-13	R-18	850	M-13	R-18-A
	15	1.82	.072	21.7	.856	21.2	.837	23.7	.936	851	M-13	R-19	852	M-13	R-19-A
	16	1.65	.065	22.1	.870	21.2	.837	23.7	.936	851	M-13	R-19	852	M-13	R-19-A
	17	1.47	.058	22.4	.884	21.9	.865	24.4	.964	855	M-13	R-21	856	M-13	R-21-A
	18	1.24	.049	22.9	.902	21.9	.865	24.4	.964	855	M-13	R-21	856	M-13	R-21-A
19	1.06	.042	23.2	.916	21.9	.865	24.4	.964	855	M-13	R-21	856	M-13	R-21-A	
20	0.88	.035	23.6	.930	21.9	.865	24.4	.964	855	M-13	R-21	856	M-13	R-21-A	
1.1/8 (28.58)	8	4.19	.165	20.1	.795	19.7	.776	22.2	.875	853	M-13	R-20	854	M-13	R-20-A
	9	3.75	.148	21.0	.829	20.5	.810	23.0	.909	849	M-13	R-18	850	M-13	R-18-A
	10	3.40	.134	21.7	.857	21.2	.837	23.7	.936	851	M-13	R-19	852	M-13	R-19-A
	11	3.04	.120	22.4	.885	21.9	.865	24.4	.964	855	M-13	R-21	856	M-13	R-21-A
	12	2.76	.109	23.0	.907	22.4	.883	24.9	.982	857	M-14	R-21	858	M-14	R-21-A
	13	2.41	.095	23.7	.935	23.2	.916	25.7	1.015	859	M-14	R-22	860	M-14	R-22-A
	14	2.10	.083	24.3	.959	23.7	.935	26.5	1.044	861	M-15	R-23	862	M-15	R-23-A
	15	1.82	.072	24.9	.981	24.4	.962	27.2	1.071	863	M-15	R-24	864	M-15	R-24-A
	16	1.65	.065	25.2	.995	24.4	.962	27.2	1.071	863	M-15	R-24	864	M-15	R-24-A
17	1.47	.058	25.6	1.010	25.1	.990	27.9	1.009	867	M-16	R-26	868	M-16	R-26-A	
18	1.24	.049	26.0	1.027	25.1	.990	27.9	1.009	867	M-16	R-26	868	M-16	R-26-A	
1.1/4 (31.75)	8	4.19	.165	23.3	.920	22.8	.901	25.6	1.010	865	M-15	R-25	866	M-15	R-25-A
	9	3.75	.148	24.2	.954	23.7	.935	26.5	1.044	861	M-15	R-23	862	M-15	R-23-A
	10	3.40	.134	24.9	.982	24.4	.962	27.2	1.071	863	M-15	R-24	864	M-15	R-24-A
	11	3.04	.120	25.6	1.010	25.1	.990	27.9	1.099	867	M-16	R-26	868	M-16	R-26-A
	12	2.76	.109	26.2	1.032	25.7	1.013	28.5	1.122	869	M-16	R-27	870	M-16	R-27-A
	13	2.41	.095	26.9	1.060	26.4	1.039	29.2	1.150	871	M-17	R-28	872	M-17	R-28-A
	14	2.10	.083	27.5	1.084	26.9	1.060	29.6	1.169	873	M-17	R-29	874	M-17	R-29-A
	15	1.82	.072	28.0	1.106	27.6	1.087	30.3	1.196	875	M-17	R-30	876	M-17	R-30-A
	16	1.65	.065	28.4	1.120	27.6	1.087	30.3	1.196	875	M-17	R-30	876	M-17	R-30-A
	17	1.47	.058	28.8	1.134	28.3	1.115	31.0	1.224	879	M-18	R-30	880	M-18	R-30-A
18	1.24	.049	29.2	1.152	28.3	1.115	31.0	1.224	879	M-18	R-30	880	M-18	R-30-A	
1.3/8 (34.92)	8	4.19	.165	26.5	1.045	26.0	1.026	28.8	1.135	877	M-17	R-31	878	M-17	R-31-A
	9	3.75	.148	27.4	1.079	26.9	1.060	29.6	1.169	873	M-17	R-29	874	M-17	R-29-A
	10	3.40	.134	28.1	1.107	27.6	1.087	30.3	1.196	875	M-17	R-30	876	M-17	R-30-A
	11	3.04	.120	28.8	1.135	28.3	1.115	31.0	1.224	879	M-18	R-30	880	M-18	R-30-A
	12	2.76	.109	29.3	1.157	28.7	1.133	31.5	1.242	881	M-18	R-32	882	M-18	R-32-A
	13	2.41	.095	30.1	1.185	29.4	1.160	32.3	1.275	883	M-19	R-33	884	M-19	R-33-A
	14	2.10	.083	30.7	1.209	29.9	1.179	32.8	1.294	885	M-20	R-34	886	M-20	R-34-A
	15	1.82	.072	31.2	1.231	30.6	1.206	33.5	1.321	887	M-20	R-35	888	M-20	R-35-A
16	1.65	.065	31.6	1.245	30.6	1.206	33.5	1.321	887	M-20	R-35	888	M-20	R-35-A	
1.1/2 (38.10)	8	4.19	.165	29.7	1.170	29.0	1.145	32.0	1.260	889	M-19	R-34	890	M-19	R-34-A
	9	3.75	.148	30.5	1.204	29.9	1.177	32.8	1.294	885	M-20	R-34	886	M-20	R-34-A
	10	3.40	.134	31.2	1.232	30.6	1.206	33.5	1.321	887	M-20	R-35	888	M-20	R-35-A
	11	3.04	.120	32.0	1.260	31.3	1.235	34.2	1.350	891	M-20	R-36	892	M-20	R-36-A
	12	2.76	.109	32.5	1.282	31.9	1.257	34.8	1.372	893	M-20	R-37	894	M-20	R-37-A
	13	2.41	.095	33.2	1.310	32.6	1.285	35.5	1.400	895	M-21	R-37	896	M-21	R-37-A
	14	2.10	.083	33.8	1.334	32.6	1.285	35.5	1.400	895	M-21	R-37	896	M-21	R-37-A
	15	1.82	.072	34.4	1.356	33.8	1.331	36.7	1.446	897	M-21	R-38	898	M-21	R-38-A
	16	1.65	.065	34.8	1.370	33.8	1.331	36.7	1.446	897	M-21	R-38	898	M-21	R-38-A
	17	1.47	.058	35.1	1.384	33.8	1.331	37.3	1.472	899	M-22	R-38	900	M-22	R-38-A
	18	1.24	.049	35.6	1.402	33.8	1.331	37.3	1.472	899	M-22	R-38	900	M-22	R-38-A
	19	1.06	.042	35.9	1.416	33.8	1.331	37.3	1.472	899	M-22	R-38	900	M-22	R-38-A
20	0.88	.035	36.3	1.430	33.8	1.331	37.3	1.472	899	M-22	R-38	900	M-22	R-38-A	

Model 797-856 expanders come with 3/8" square mandrel drives and Model 857-900 expanders come with 1/2" square mandrel drives.

800-5 SERIES FIVE ROLL FOR THIN WALL TUBES

5/8" - 1 1/2"
O.D.

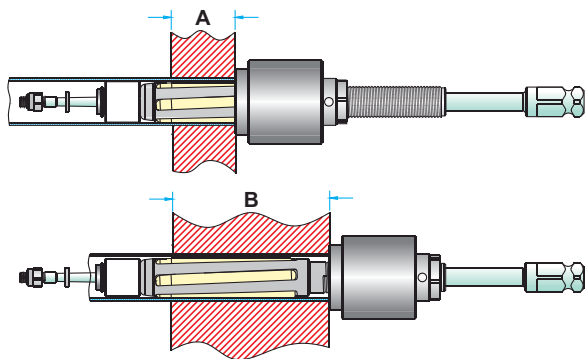

FOR TUBES INTERNAL DIAMETER FROM (12.9 mm) .509" TO (36.7 mm) 1.44"

TUBE EXPANDERS FITTED WITH ROLLER LENGTH	FOR TUBE SHEET ADJUSTABLE RANGE	
	MINIMUM A	MAXIMUM B
(38.1mm)	(12.7mm) 1/2"	(38.1mm) 1.1/2"
(57.1mm) 2.1/4"	(31.7mm) 1.1/4"	(57.1mm) 2.1/4"

- Use : Highly recommended for use on thin walled tubes (19 thru 22 gage walls) of Stainless Steel, Titanium, Incoloy and other exotic materials.
- Advantages : Gives a more concentric and even expansion when expanding thin walled tubes vs. a conventional 3 roll expander and reduces tube spring back effect.

Tube O.D. (mm) inch	Tube Thickness			Tube I.D.		Minimum I.D. Tool Enters		Maximum Expansion of Tool		EXPANDER with (38.10 mm) 1.1/2" Long Rollers			EXPANDER with (57.15 mm) 2.1/4" Long Rollers		
	bwg	mm	inch	mm	inch	mm	inch	mm	inch	Complete Tool No.	Mandrel No.	Rollers Set. No.	Complete Tool No.	Mandrel No.	Rollers Set. No.
5/8 (15.88)	17	1.47	.058	12.9	.509	12.6	.499	14.3	.564	815-5	816-5	R-4-5	816-5	816-5	R-4-A-5
	18	1.24	.049	13.4	.527	13.1	.517	14.6	.576	817-5	M-9	R-4-5	-	-	-
	19	1.06	.042	13.7	.541	13.3	.522	14.8	.582	819-5	820-5	R-4-5	820-5	820-5	R-4-A-5
	20	0.88	.035	14.1	.555	13.6	.536	15.1	.596	819-5 S	820-S	R-4-5	820-5 S	820-S	R-4-A-5
	21	0.81	.032	14.2	.561	13.6	.536	15.1	.596	819-5 S	820-S	R-4-5	820-5 S	820-S	R-4-A-5
3/4 (19.05)	22	0.71	.028	14.5	.569	13.6	.536	15.1	.596	819-5 S	820-S	R-4-5	820-5 S	820-S	R-4-A-5
	13	2.41	.095	14.2	.560	13.9	.550	15.6	.615	821-5	822-5	R-5-5	822-5	822-5	R-5-A-5
	14	2.10	.083	14.8	.584	14.5	.574	15.9	.629	823-5	824-5	R-6-5	824-5	824-5	R-6-A-5
	15	1.82	.072	15.3	.606	14.9	.590	16.8	.661	825-5	826-5	R-7-5	826-5	826-5	R-7-A-5
	16	1.65	.065	15.7	.620	15.3	.605	17.2	.680	827-5	M-13	R-7-5	828-5	M-13	R-7-A-5
	17	1.47	.058	16.1	.634	15.7	.619	17.8	.699	829-5	830-5	R-7-5	830-5	830-5	R-7-A-5
	18	1.24	.049	16.5	.652	15.7	.619	17.8	.699	829-5	830-5	R-7-5	830-5	830-5	R-7-A-5
	19	1.06	.042	16.9	.666	16.3	.642	18.5	.729	831-5	M-13	R-9-5	832-5	M-13	R-9-A-5
	20	0.88	.035	17.2	.680	16.3	.642	18.5	.729	831-5	M-13	R-9-5	832-5	M-13	R-9-A-5
	21	0.81	.032	17.4	.686	16.3	.642	18.5	.729	831-5	M-13	R-9-5	832-5	M-13	R-9-A-5
22	0.71	.028	17.6	.694	16.3	.642	18.5	.729	831-5	M-13	R-9-5	832-5	M-13	R-9-A-5	
23	0.64	.025	17.8	.700	17.0	.670	18.9	.747	833-5	M-14-3/8	R-9-5	834-5	M-14-3/8	R-9-A-5	
24	0.56	.022	17.9	.706	17.0	.670	18.9	.747	833-5	M-14-3/8	R-9-5	834-5	M-14-3/8	R-9-A-5	
25	0.51	.020	18.0	.710	17.4	.685	19.0	.750	835-5	M-15-3/8	R-10-5	836-5	M-15-3/8	R-10-A-5	

For best results a 'Thin Wall Thrust Collar' should be used when rolling 19 thru 22 gauge wall tubes.

Model 815-5 - 858-5 come with 3/8" square mandrel drives and Model 859-5 - 900-5 come with 1/2" square mandrel drives.



800-5 SERIES FIVE ROLL FOR THIN WALL TUBES

Tube O.D. (mm) inch	Tube Thickness			Tube I.D.		Minimum I.D. Tool Enters		Maximum Expansion of Tool		EXPANDER with (38.10 mm) 1.1/2" Long Rollers			EXPANDER with (57.15 mm) 2.1/4" Long Rollers		
	bwg	mm	inch	mm	inch	mm	inch	mm	inch	Complete Tool No.	Mandrel No.	Rollers Set. No.	Complete Tool No.	Mandrel No.	Rollers Set. No.
(22.22) 7/8	13	2.41	.095	17.4	.685	17.0	.670	18.9	.747	833-5	M-14-3/8	R-9-5	834-5	M-14-3/8	R-9-A-5
	14	2.10	.083	18.0	.709	17.4	.685	19.0	.750	835-5	M-15-3/8	R-10-5	836-5	M-15-3/8	R-10-A-5
	16	1.65	.065	18.9	.745	18.4	.726	20.3	.800	839-5	840-5	R-11-5	840-5	840-5	R-11-A-5
	17	1.47	.058	19.2	.759	18.8	.740	20.9	.824	843-5	M-17-3/8	R-11-5	844-5	M-17-3/8	R-11-A-5
	18	1.24	.049	19.7	.777	18.8	.740	20.9	.824	843-5	M-17-3/8	R-11-5	844-5	M-17-3/8	R-11-A-5
	19	1.07	.042	20.1	.791	19.4	.763	21.6	.851	845-5	M-18-3/8	R-11-5	846-5	M-18-3/8	R-11-A-5
	20	0.89	.035	20.4	.805	19.4	.763	21.6	.851	845-5	M-18-3/8	R-11-5	846-5	M-18-3/8	R-11-A-5
	21	0.81	.032	20.6	.811	19.4	.763	21.6	.851	845-5	M-18-3/8	R-11-5	846-5	M-18-3/8	R-11-A-5
	22	0.71	.028	20.8	.819	19.4	.763	21.6	.851	845-5	M-18-3/8	R-11-5	846-5	M-18-3/8	R-11-A-5
(25.40) 1	23	0.64	.025	20.9	.825	20.1	.791	22.4	.880	847-5	M-18-3/8	R-13-5	848-5	M-18-3/8	R-13-A-5
	24	0.56	.022	21.1	.831	20.1	.791	22.4	.880	847-5	M-18-3/8	R-13-5	848-5	M-18-3/8	R-13-A-5
	12	2.76	.109	19.8	.782	19.4	.763	21.6	.852	845-5	M-18-3/8	R-11-5	846-5	M-18-3/8	R-11-A-5
	13	2.41	.095	20.5	.810	20.1	.791	22.4	.880	847-5	M-18-3/8	R-13-5	848-5	M-18-3/8	R-13-A-5
	14	2.10	.083	21.2	.834	20.5	.810	22.3	.879	849-5	850-5	R-12-5	850-5	850-5	R-12-A-5
	15	1.82	.072	21.7	.856	21.3	.837	23.8	.936	851-5	852-5	R-13-5	852-5	852-5	R-13-A-5
	16	1.65	.065	22.0	.870	21.3	.837	23.8	.936	851-5	852-5	R-13-5	852-5	852-5	R-13-A-5
	17	1.47	.058	22.4	.884	22.0	.865	24.5	.965	855-5	856-5	R-13-5	856-5	856-5	R-13-A-5
	18	1.24	.049	22.9	.902	22.0	.865	24.5	.965	855-5	856-5	R-13-5	856-5	856-5	R-13-A-5
	19	1.06	.042	23.2	.916	22.0	.865	24.5	.965	855-5	856-5	R-13-5	856-5	856-5	R-13-A-5
	20	0.88	.035	23.6	.930	22.0	.865	24.5	.965	855-5	856-5	R-13-5	856-5	856-5	R-13-A-5
	21	0.81	.032	23.8	.936	22.4	.883	25.3	.997	857-5	M-21-3/8	R-15-5	858-5	M-21-3/8	R-15-A-5
(28.58) 1.1/8	22	0.71	.028	24.0	.944	22.4	.883	25.3	.997	857-5	M-21-3/8	R-15-5	858-5	M-21-3/8	R-15-A-5
	23	0.64	.025	24.1	.950	22.4	.883	25.3	.997	857-5	M-21-3/8	R-15-5	858-5	M-21-3/8	R-15-A-5
	24	0.56	.022	24.3	.956	22.4	.883	25.3	.997	857-5	M-21-3/8	R-15-5	858-5	M-21-3/8	R-15-A-5
	25	0.51	.020	24.4	.960	22.4	.883	25.3	.997	857-5	M-21-3/8	R-15-5	858-5	M-21-3/8	R-15-A-5
	12	2.76	.109	23.0	.907	22.4	.883	25.3	.997	857-5	M-21-3/8	R-15-5	858-5	M-21-3/8	R-15-A-5
	13	2.41	.095	23.7	.935	23.2	.916	25.4	1.000	859-5	860-5	R-16-5	860-5	860-5	R-16-A-5
	14	2.11	.083	24.3	.959	23.7	.935	26.4	1.039	861-5	862-5	R-17-5	862-5	862-5	R-17-A-5
	22	0.71	.028	27.2	1.069	26.4	1.039	29.4	1.157	871-5	872-5	R-19-5	872-5	872-5	R-19-A-5
	24	0.56	.022	27.5	1.081	26.4	1.039	29.4	1.157	871-5	872-5	R-19-5	872-5	872-5	R-19-A-5
	(31.75) 1.1/4	15	1.82	.072	28.1	1.106	27.6	1.087	30.4	1.196	875-5	876-5	R-21-5	876-5	876-5
16		1.65	.065	28.4	1.120	27.6	1.087	30.4	1.196	875-5	876-5	R-21-5	876-5	876-5	R-21-A-5
17		1.47	.058	28.8	1.134	28.3	1.115	31.3	1.231	879-5	880-5	R-21-5	880-5	880-5	R-21-A-5
18		1.24	.049	29.3	1.152	28.3	1.115	31.3	1.231	879-5	880-5	R-21-5	880-5	880-5	R-21-A-5
19		1.07	.042	29.6	1.166	28.3	1.115	31.3	1.231	879-5	880-5	R-21-5	880-5	880-5	R-21-A-5
20		0.88	.035	30.0	1.180	28.3	1.115	31.3	1.231	879-5	880-5	R-21-5	880-5	880-5	R-21-A-5
21		0.81	.032	30.1	1.186	28.3	1.115	31.3	1.231	879-5	880-5	R-21-5	880-5	880-5	R-21-A-5
22		0.71	.028	30.3	1.194	28.3	1.115	31.3	1.231	879-5	880-5	R-21-5	880-5	880-5	R-21-A-5
23		0.64	.025	30.5	1.200	28.8	1.133	31.5	1.242	881-5	882-5	R-21-5	882-5	882-5	R-21-A-5
(34.92) 1.3/8	24	0.56	.022	30.6	1.206	28.8	1.133	31.5	1.242	881-5	882-5	R-21-5	882-5	882-5	R-21-A-5
	12	2.76	.109	29.3	1.154	28.8	1.133	31.5	1.242	881-5	882-5	R-21-5	882-5	882-5	R-21-A-5
	14	2.11	.083	30.7	1.209	29.9	1.179	32.9	1.296	885-5	882-5	R-23-5	882-5	882-5	R-23-A-5
	20	0.88	.035	33.2	1.305	31.9	1.257	35.2	1.385	893-5	894-5	R-26-5	894-5	894-5	R-26-A-5
	22	0.71	.028	33.5	1.319	32.6	1.285	36.0	1.417	895-5	896-5	R-26-5	896-5	896-5	R-26-A-5
(38.10) 1.1/2	24	0.56	.022	33.8	1.331	32.6	1.285	36.0	1.417	895-5	896-5	R-26-5	896-5	896-5	R-26-A-5
	17	1.47	.058	35.1	1.384	33.8	1.331	37.8	1.489	899-5	900-5	R-29-5	900-5	900-5	R-29-A-5
	18	1.24	.049	35.6	1.402	33.8	1.331	37.8	1.489	899-5	900-5	R-29-5	900-5	900-5	R-29-A-5
	19	1.06	.042	36.0	1.416	33.8	1.331	37.8	1.489	899-5	900-5	R-29-5	900-5	900-5	R-29-A-5
	20	0.89	.035	36.3	1.430	33.8	1.331	37.8	1.489	899-5	900-5	R-29-5	900-5	900-5	R-29-A-5
	21	0.81	.032	36.5	1.436	33.8	1.331	37.8	1.489	899-5	900-5	R-29-5	900-5	900-5	R-29-A-5
	22	0.71	.028	36.7	1.444	33.8	1.331	37.8	1.489	899-5	900-5	R-29-5	900-5	900-5	R-29-A-5
	23	0.64	.025	36.8	1.450	33.8	1.331	37.8	1.489	899-5	900-5	R-29-5	900-5	900-5	R-29-A-5
24	0.56	.022	37.0	1.456	33.8	1.331	37.8	1.489	899-5	900-5	R-29-5	900-5	900-5	R-29-A-5	

For best results a 'Thin Wall Thrust Collar' should be used when rolling 19 thru 22 gauge wall tubes.
 Model 815-5 - 858-5 come with 3/8" square mandrel drives and Model 859-5 - 900-5 come with 1/2" square mandrel drives.

1200 SERIES LONG REACH

1/2" - 1 1/2"
O.D.

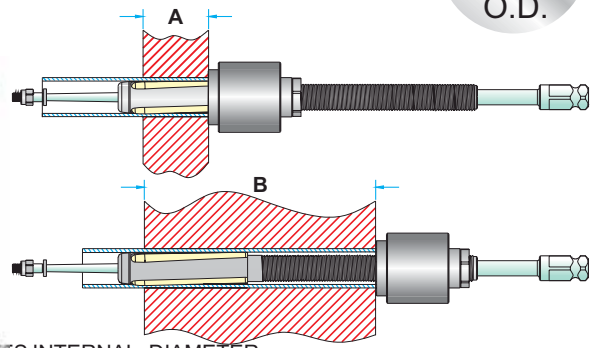

FOR TUBE'S INTERNAL DIAMETER
FROM (8.4 mm) .334" TO (36.3 mm) 1.43"

- Use : Most popular tool worldwide for heat exchangers and condensers with tubes of 5/8"-1.1/2" O.D. and thick tube sheets.
- Longer reach expanders are available. Please let us know reach needed.

	TUBE EXPANDERS FITTED WITH ROLLER LENGTH	FOR TUBE SHEET ADJUSTABLE RANGE	
		MINIMUM A	MAXIMUM B
	STD. REACH "A" REACH "B" REACH "C" REACH	(38.1mm) 1.1/2" (38.1mm) 1.1/2" (38.1mm) 1.1/2" (38.1mm) 1.1/2"	(152.4mm) 6" (203.2mm) 8" (253.8mm) 10" (304.6mm) 12"
(57.1mm) 2.1/4"	STD. REACH "A" REACH "B" REACH "C" REACH	(57.1mm) 2.1/4" (57.1mm) 2.1/4" (57.1mm) 2.1/4" (57.1mm) 2.1/4"	(171.4mm) 6.3/4" (222.1mm) 8.3/4" (272.8mm) 10.3/4" (323.6mm) 12.3/4"

Tube O.D. (mm) inch	Tube Thickness			Tube I.D.		Minimum I.D. Tool Enters		Maximum Expansion of Tool		EXPANDER with (38.10 mm) 1.1/2" Long Rollers			EXPANDER with (57.15 mm) 2.1/4" Long Rollers		
	bwg	mm	inch	mm	inch	mm	inch	mm	inch	Complete Tool No.	Mandrel No.	Rollers Set. No.	Complete Tool No.	Mandrel No.	Rollers Set. No.
(12.70)	14	2.10	.083	8.4	.334	8.2	.324	9.5	.374	1197	1197	797	-	-	-
	15	1.82	.072	9.0	.356	8.8	.348	10.1	.398	1199	1199	R-1	-	-	-
	16	1.65	.065	9.4	.370	9.1	.360	10.4	.410	1201	M-51	R-1	-	-	-
	17	1.47	.058	9.7	.384	9.5	.374	10.7	.424	1203	M-51	R-2	-	-	-
	18	1.24	.049	10.2	.402	9.9	.392	11.3	.447	1205	M-52	R-3	-	-	-
(15.88)	20	0.88	.035	10.9	.430	10.3	.406	11.7	.461	1205S	M-53	R-3	-	-	-
	12	2.76	.109	10.3	.407	9.9	.392	11.3	.447	1205	M-52	R-3	-	-	-
	13	2.41	.095	11.0	.435	10.8	.425	12.1	.480	1207	M-53	R-4	-	-	-
	14	2.10	.083	11.6	.459	11.4	.449	12.9	.509	1209	M-54	R-4	1210	M-54	R-4-A
	15	1.82	.072	12.2	.481	11.9	.471	13.6	.536	1211	M-55	R-5	1212	M-55	R-5-A
	16	1.65	.065	12.5	.495	12.3	.485	13.9	.550	1213	M-55	R-6	1214	M-55	R-6-A
	17	1.47	.058	12.9	.509	12.6	.499	14.3	.564	1215	M-56	R-6	1216	M-56	R-6-A
	18	1.24	.049	13.3	.527	13.1	.517	14.5	.572	1217	M-57	R-7	1218	M-57	R-7-A
	19	1.06	.042	13.7	.541	13.2	.522	14.7	.582	1219	M-56	R-7	1220	M-56	R-7-A
	20	0.88	.035	14.1	.555	13.6	.536	15.1	.596	1219 S	M-58	R-7	1220 S	M-58	R-7-A
(19.05)	21	0.81	.032	14.2	.561	13.6	.536	15.1	.596	1219 S	M-58	R-7	1220 S	M-58	R-7-A
	22	0.71	.028	14.4	.569	13.6	.536	15.1	.596	1219 S	M-58	R-7	1220 S	M-58	R-7-A
	10	3.40	.134	12.2	.482	11.9	.471	13.6	.536	1211	M-55	R-5	1212	M-55	R-5-A
	11	3.04	.120	12.9	.510	12.6	.499	14.3	.564	1215	M-56	R-6	1216	M-56	R-6-A
	12	2.76	.109	13.5	.532	13.2	.522	14.7	.582	1219	M-56	R-7	1220	M-56	R-7-A
	13	2.41	.095	14.2	.560	13.9	.550	15.6	.615	1221	M-58	R-8	1222	M-58	R-8-A
	14	2.10	.083	14.8	.584	14.5	.574	16.2	.639	1223	M-58	R-9	1224	M-58	R-9-A
	15	1.82	.072	15.3	.606	15.1	.596	16.7	.661	1225	M-58	R-10	1226	M-58	R-10-A
	16	1.65	.065	15.7	.620	15.3	.605	17.4	.685	1227	M-59	R-10	1228	M-59	R-10-A
	17	1.47	.058	16.1	.634	15.7	.619	17.7	.699	1229	M-59	R-11	1230	M-59	R-11-A
(22.22)	18	1.24	.049	16.5	.652	15.7	.619	17.7	.699	1229	M-59	R-11	1230	M-59	R-11-A
	19	1.06	.042	16.9	.666	16.3	.642	18.3	.722	1231	M-59	R-12	1232	M-59	R-12-A
	20	0.88	.035	17.2	.680	16.3	.642	18.3	.722	1231	M-59	R-12	1232	M-59	R-12-A
	21	0.81	.032	17.4	.686	16.3	.642	18.3	.722	1231	M-59	R-12	1232	M-59	R-12-A
	22	0.71	.028	17.6	.694	16.3	.642	18.3	.722	1231	M-59	R-12	1232	M-59	R-12-A
	10	3.40	.134	15.4	.607	15.1	.596	16.7	.661	1225	M-58	R-10	1226	M-58	R-10-A
	11	3.04	.120	16.1	.635	15.7	.619	17.7	.699	1229	M-59	R-11	1230	M-59	R-11-A
	12	2.76	.109	16.6	.657	16.3	.642	18.3	.722	1231	M-59	R-12	1232	M-59	R-12-A
	13	2.41	.095	17.4	.685	17.0	.670	19.0	.750	1233	M-60	R-13	1234	M-60	R-13-A
	14	2.10	.083	18.0	.709	17.4	.685	19.6	.774	1235	M-61	R-14	1236	M-61	R-14-A
15	1.82	.072	18.5	.731	18.0	.712	20.3	.801	1237	M-61	R-15	1238	M-61	R-15-A	
16	1.65	.065	18.9	.745	18.4	.726	20.7	.815	1239	M-62	R-15	1240	M-62	R-15-A	
17	1.47	.058	19.2	.759	18.8	.740	21.0	.829	1243	M-62	R-16	1244	M-62	R-16-A	
18	1.24	.049	19.7	.777	18.8	.740	21.0	.829	1243	M-62	R-16	1244	M-62	R-16-A	

Model 1197-1256 expanders come with 3/8" square mandrel drives and Model 1257-1300 expanders come with 1/2" square mandrel drives.



1200 SERIES LONGREACH

Tube O.D. (mm) inch	Tube Thickness			Tube I.D.		Minimum I.D. Tool Enters		Maximum Expansion of Tool		EXPANDER with (38.10 mm) 1.1/2" Long Rollers			EXPANDER with (57.15 mm) 2.1/4" Long Rollers		
	bwg	mm	inch	mm	inch	mm	inch	mm	inch	Complete Tool No.	Mandrel No.	Rollers Set. No.	Complete Tool No.	Mandrel No.	Rollers Set. No.
1	8	4.19	.165	17.0	.670	16.6	.655	18.6	.735	1241	M-59	R-13	1242	M-59	R-13-A
	9	3.75	.148	17.8	.704	17.4	.685	19.6	.774	1235	M-61	R-14	1236	M-61	R-14-A
	10	3.40	.134	18.5	.732	18.0	.712	20.3	.801	1237	M-61	R-15	1238	M-61	R-15-A
	11	3.04	.120	19.3	.760	18.8	.740	21.0	.829	1243	M-62	R-16	1244	M-62	R-16-A
	12	2.76	.109	19.8	.782	19.3	.763	21.6	.852	1245	M-62	R-17	1246	M-62	R-17-A
	13	2.41	.095	20.5	.810	20.0	.791	22.3	.880	1247	M-62	R-18	1248	M-62	R-18-A
	14	2.10	.083	21.1	.834	20.5	.810	23.0	.909	1249	M-63	R-18	1250	M-63	R-18-A
	15	1.82	.072	21.7	.856	21.2	.837	23.7	.936	1251	M-63	R-19	1252	M-63	R-19-A
	16	1.65	.065	22.1	.870	21.2	.837	23.7	.936	1251	M-63	R-19	1252	M-63	R-19-A
	17	1.47	.058	22.4	.884	21.9	.865	24.4	.964	1255	M-63	R-21	1256	M-63	R-21-A
	18	1.24	.049	22.9	.902	21.9	.865	24.4	.964	1255	M-63	R-21	1256	M-63	R-21-A
19	1.06	.042	23.2	.916	21.9	.865	24.4	.964	1255	M-63	R-21	1256	M-63	R-21-A	
20	0.88	.035	23.6	.930	21.9	.865	24.4	.964	1255	M-63	R-21	1256	M-63	R-21-A	
1.1/8	8	4.19	.165	20.1	.795	19.7	.776	22.2	.875	1253	M-63	R-20	1254	M-63	R-20-A
	9	3.75	.148	21.0	.829	20.5	.810	23.0	.909	1249	M-63	R-18	1250	M-63	R-18-A
	10	3.40	.134	21.7	.857	21.2	.837	23.7	.936	1251	M-63	R-19	1252	M-63	R-19-A
	11	3.04	.120	22.4	.885	21.9	.865	24.4	.964	1255	M-63	R-21	1256	M-63	R-21-A
	12	2.76	.109	23.0	.907	22.4	.883	24.9	.982	1257	M-64	R-21	1258	M-64	R-21-A
	13	2.41	.095	23.7	.935	23.2	.916	25.7	1.015	1259	M-64	R-22	1260	M-64	R-22-A
	14	2.10	.083	24.3	.959	23.7	.935	26.5	1.044	1261	M-65	R-23	1262	M-65	R-23-A
	15	1.82	.072	24.9	.981	24.4	.962	27.2	1.071	1263	M-65	R-24	1264	M-65	R-24-A
1.1/4	16	1.65	.065	25.2	.995	24.4	.962	27.2	1.071	1263	M-65	R-24	1264	M-65	R-24-A
	17	1.47	.058	25.6	1.010	25.1	.990	27.9	1.099	1267	M-66	R-26	1268	M-66	R-26-A
	18	1.24	.049	26.0	1.027	25.1	.990	27.9	1.099	1267	M-66	R-26	1268	M-66	R-26-A
	8	4.19	.165	23.3	.920	22.8	.901	25.6	1.010	1265	M-65	R-25	1266	M-65	R-25-A
	9	3.75	.148	24.2	.954	23.7	.935	26.5	1.044	1261	M-65	R-23	1262	M-65	R-23-A
	10	3.40	.134	24.9	.982	24.4	.962	27.2	1.071	1263	M-65	R-24	1264	M-65	R-24-A
	11	3.04	.120	25.6	1.010	25.1	.990	27.9	1.099	1267	M-66	R-26	1268	M-66	R-26-A
	12	2.76	.109	26.2	1.032	25.7	1.013	28.5	1.122	1269	M-66	R-27	1270	M-66	R-27-A
1.3/8	13	2.41	.095	26.9	1.060	26.4	1.039	29.2	1.150	1271	M-67	R-28	1272	M-67	R-28-A
	14	2.10	.083	27.5	1.084	26.9	1.060	29.6	1.169	1273	M-67	R-29	1274	M-67	R-29-A
	15	1.82	.072	28.0	1.106	27.6	1.087	30.3	1.196	1275	M-67	R-30	1276	M-67	R-30-A
	16	1.65	.065	28.4	1.120	27.6	1.087	30.3	1.196	1275	M-67	R-30	1276	M-67	R-30-A
	17	1.47	.058	28.8	1.134	28.3	1.115	31.0	1.224	1279	M-68	R-30	1280	M-68	R-30-A
	18	1.24	.049	29.2	1.152	28.3	1.115	31.0	1.224	1279	M-68	R-30	1280	M-68	R-30-A
1.3/8	8	4.19	.165	26.5	1.045	26.0	1.026	28.8	1.135	1277	M-67	R-31	1278	M-67	R-31-A
	9	3.75	.148	27.4	1.079	26.9	1.060	29.6	1.169	1273	M-67	R-29	1274	M-67	R-29-A
	10	3.40	.134	28.1	1.107	27.6	1.087	30.3	1.196	1275	M-67	R-30	1276	M-67	R-30-A
	11	3.04	.120	28.8	1.135	28.3	1.115	31.0	1.224	1279	M-68	R-30	1280	M-68	R-30-A
	12	2.76	.109	29.3	1.157	28.7	1.133	31.5	1.242	1281	M-68	R-32	1282	M-68	R-32-A
	13	2.41	.095	30.1	1.185	29.4	1.160	32.3	1.275	1283	M-69	R-33	1284	M-69	R-33-A
	14	2.10	.083	30.7	1.209	29.9	1.179	32.8	1.294	1285	M-70	R-34	1286	M-70	R-34-A
1.1/2	15	1.82	.072	31.2	1.231	30.6	1.206	33.5	1.321	1287	M-70	R-35	1288	M-70	R-35-A
	16	1.65	.065	31.6	1.245	30.6	1.206	33.5	1.321	1287	M-70	R-35	1288	M-70	R-35-A
	8	4.19	.165	29.7	1.170	29.0	1.145	32.0	1.260	1289	M-69	R-34	1290	M-69	R-34-A
	9	3.75	.148	30.5	1.204	29.9	1.177	32.8	1.294	1285	M-70	R-34	1286	M-70	R-34-A
	10	3.40	.134	31.2	1.232	30.6	1.206	33.5	1.321	1287	M-70	R-35	1288	M-70	R-35-A
	11	3.04	.120	32.0	1.260	31.3	1.235	34.2	1.350	1291	M-70	R-36	1292	M-70	R-36-A
	12	2.76	.109	32.5	1.282	31.9	1.257	34.8	1.372	1293	M-70	R-37	1294	M-70	R-37-A
	13	2.41	.095	33.2	1.310	32.6	1.285	35.5	1.400	1295	M-71	R-37	1296	M-71	R-37-A
	14	2.10	.083	33.8	1.334	32.6	1.285	35.5	1.400	1295	M-71	R-37	1296	M-71	R-37-A
	15	1.82	.072	34.4	1.356	33.8	1.331	36.7	1.446	1297	M-71	R-38	1298	M-71	R-38-A
	16	1.65	.065	34.8	1.370	33.8	1.331	36.7	1.446	1297	M-71	R-38	1298	M-71	R-38-A
17	1.47	.058	35.1	1.384	33.8	1.331	37.3	1.472	1299	M-72	R-38	1300	M-72	R-38-A	
18	1.24	.049	35.6	1.402	33.8	1.331	37.3	1.472	1299	M-72	R-38	1300	M-72	R-38-A	
19	1.06	.042	35.9	1.416	33.8	1.331	37.3	1.472	1299	M-72	R-38	1300	M-72	R-38-A	
20	0.88	.035	36.3	1.430	33.8	1.331	37.3	1.472	1299	M-72	R-38	1300	M-72	R-38-A	

Model 1197-1256 expanders come with 3/8" square mandrel drives and Model 1257-1300 expanders come with 1/2" square mandrel drives.

1200-5 SERIES FIVE ROLL FORTHIN WALL TUBES

$\frac{3}{4}$ " - $1\frac{1}{2}$ "
O.D.

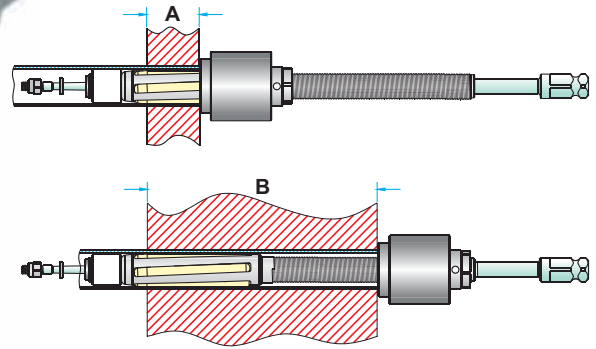

FOR TUBES INTERNADIAMETER
FROM (14.8 mm) .584" TO (36.3 mm) 1.43"

TUBE EXPANDERS FITTED WITH ROLLER LENGTH		FOR TUBE SHEET ADJUSTABLE RANGE	
		MINIMUM A	MAXIMUM B
(38.1mm)	STD. REACH	(38.1mm) 1.1/2"	(152.4mm) 6"
	"A" REACH	(38.1mm) 1.1/2"	(203.2mm) 8"
	"B" REACH	(38.1mm) 1.1/2"	(253.8mm) 10"
	"C" REACH	(38.1mm) 1.1/2"	(304.6mm) 12"
(57.1mm) 2.1/4"	STD. REACH	(57.1mm) 2.1/4"	(171.4mm) 6.3/4"
	"A" REACH	(57.1mm) 2.1/4"	(222.1mm) 8.3/4"
	"B" REACH	(57.1mm) 2.1/4"	(272.8mm) 10.3/4"
	"C" REACH	(57.1mm) 2.1/4"	(323.6mm) 12.3/4"

- Use : Highly recommended for use on thin walled tubes (19 thru 22 gage walls) of Stainless Steel, Titanium, Incoloy and other exotic materials in thick tube sheets.
- Advantages : Gives a more concentric and even expansion when expanding thin walled tubes vs. a conventional 3 roll expander and reduces tube spring back effect.
- Expanders for tube sizes not listed below are also available. Please enquire.

Tube O.D. (mm) inch	Tube Thickness			Tube I.D.		Minimum I.D. Tool Enters		Maximum Expansion of Tool		EXPANDER with (38.10 mm) 1.1/2" Long Rollers			EXPANDER with (57.15) 2.1/4" Long Rollers		
	bwg	mm	inch	mm	inch	mm	inch	mm	inch	Complete Tool No.	Mandrel No.	Rollers Set. No.	Complete Tool No.	Mandrel No.	Rollers Set. No.
(19.05) 3/4	14	2.10	.083	14.8	.584	14.5	.574	16.2	.639	1223-5	1224-5	R-6-5	1224-5	1224-5	R-6-A-5
	15	1.82	.072	15.3	.606	14.9	.590	16.7	.661	1225-5	1226-5	R-7-5	1226-5	1226-5	R-7-A-5
	16	1.65	.065	15.7	.620	15.3	.605	17.4	.685	1227-5	M-63	R-7-5	1228-5	M-63	R-7-A-5
	17	1.47	.058	16.1	.634	15.7	.619	17.8	.699	1229-5	1230-5	R-7-5	1230-5	1230-5	R-7-A-5
	18	1.24	.049	16.5	.652	15.7	.619	17.8	.699	1229-5	1230-5	R-7-5	1230-5	1230-5	R-7-A-5
	19	1.06	.042	16.9	.666	16.3	.642	18.5	.722	1231-5	M-63	R-9-5	1232-5	M-63	R-9-A-5
	20	0.88	.035	17.2	.680	16.3	.642	18.5	.722	1231-5	M-63	R-9-5	1232-5	M-63	R-9-A-5
	21	0.81	.032	17.4	.686	16.3	.642	18.5	.722	1231-5	M-63	R-9-5	1232-5	M-63	R-9-A-5
(25.40) 1	22	0.71	.028	17.6	.694	16.3	.642	18.5	.722	1231-5	M-63	R-9-5	1232-5	M-63	R-9-A-5
	14	2.10	.083	21.1	.834	20.5	.810	23.0	.909	1249-5	1250-5	R-12-5	1250-5	1250-5	R-12-A-5
	15	1.82	.072	21.7	.856	21.2	.837	23.7	.936	1251-5	1251-5	R-13-5	1252-5	1251-5	R-13-A-5
	16	1.65	.065	22.0	.870	21.2	.837	23.7	.936	1251-5	1251-5	R-13-5	1252-5	1251-5	R-13-A-5
	17	1.47	.058	22.4	.884	21.9	.865	24.4	.964	1255-5	1256-5	R-13-5	1256-5	1256-5	R-13-A-5
	18	1.24	.049	22.9	.902	21.9	.865	24.4	.964	1255-5	1256-5	R-13-5	1256-5	1256-5	R-13-A-5
	19	1.06	.042	23.2	.916	21.9	.865	24.4	.964	1255-5	1256-5	R-13-5	1256-5	1256-5	R-13-A-5
	20	0.88	.035	23.6	.930	21.9	.865	24.4	.964	1255-5	1256-5	R-13-5	1256-5	1256-5	R-13-A-5
(28.58) 1.1/8	21	0.81	.032	23.8	.936	22.4	.883	24.9	.982	1257-5	M-71-3/8	R-15-5	1258-5	M-71-3/8	R-15-A-5
	22	0.71	.028	24.0	.944	22.4	.883	24.9	.982	1257-5	M-71-3/8	R-15-5	1258-5	M-71-3/8	R-15-A-5
	12	2.76	.109	23.0	.907	22.4	.883	24.9	.982	1257-5	M-71-3/8	R-15-5	1258-5	M-71-3/8	R-15-A-5
(38.10) 1.1/2	15	1.82	.072	24.9	.981	24.4	.962	27.2	1.071	1263-5	1263-5	R-18-5	-	-	-
	16	1.65	.065	25.2	.995	24.4	.962	27.2	1.071	1263-5	1263-5	R-18-5	-	-	-
	17	1.47	.058	35.1	1.384	33.8	1.331	37.3	1.472	1299-5	1299-5	R-29-5	1300-5	1299-5	R-29-A-5
	18	1.24	.049	35.6	1.402	33.8	1.331	37.3	1.472	1299-5	1299-5	R-29-5	1300-5	1299-5	R-29-A-5
	19	1.06	.042	36.0	1.416	33.8	1.331	37.3	1.472	1299-5	1299-5	R-29-5	1300-5	1299-5	R-29-A-5
	20	0.89	.035	36.3	1.430	33.8	1.331	37.3	1.472	1299-5	1299-5	R-29-5	1300-5	1299-5	R-29-A-5

For best results a 'Thin Wall Thrust Collar' should be used when rolling 19 thru 22 gauge wall tubes.

Model 1223-5 - 1258-5 expanders come with 3/8" square mandrel drives and Model 1263-5 - 1300-5 expanders come with 1/2" square mandrel drives.

1 3/4" - 5"
O.D.

8012 SERIES

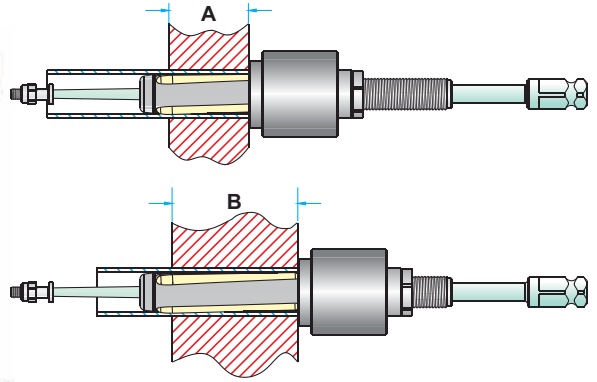

FOR TUBES INTERNAL DIAMETER
FROM (35.1 mm) 1.420" TO (123.7 mm) 4.870"

TUBE EXPANDERS FITTED WITH ROLLER LENGTH	FOR TUBE SHEET ADJUSTABLE RANGE	
	MINIMUM A	MAXIMUM B
2.1/4" (57.1mm)	STD. REACH (12.7mm) 1/2"	(101.4mm) 4"
	- 6" REACH (12.7mm) 1/2"	(152.4mm) 6"
	- 8" REACH (12.7mm) 1/2"	(203.2mm) 8"

For Mandrels in 6" and 8" reach suffix -6" or -8" to the mandrel model number.

- Use : To expand tubes in Air Heaters, Boilers and Refinery still tubes. Can be used to expand thick tube sheets (upto 8").
- For Larger Size '8012' series expanders, please contact us.

Tube O.D. (mm) inch	Tube Thickness		Tube I.D.		Minimum I.D. Tool Enters		Maximum Expansion of Tool		EXPANDER with (57.15 mm) 2.1/4" Long Rollers			
	bwg	mm	inch	mm	inch	mm	inch	mm	inch	Complete Tool No.	Mandrel No.	Rollers Set. No.
(44.45)	8	4.19	.165	36.1	1.420	34.7	1.368	39.3	1.550	8012-1.3/4-8	M-90	R-33-A
	10	3.40	.134	37.6	1.482	36.0	1.420	40.8	1.607	8012-1.3/4-10	M-90	R-37-A
	11	3.04	.120	38.3	1.510	36.9	1.454	41.5	1.635	8012-1.3/4-11	M-90	R-42
	12	2.76	.109	38.9	1.532	37.6	1.482	42.0	1.657	8012-1.3/4-12	M-90	R-44
	13	2.41	.095	39.6	1.560	38.3	1.510	42.7	1.685	8012-1.3/4-13	M-90	R-46
	14	2.10	.083	40.2	1.584	38.9	1.532	43.4	1.709	8012-1.3/4-14	M-90	R-48
(50.80)	7	4.57	.180	41.6	1.640	39.8	1.570	45.0	1.770	8012-2-7	M-91	R-46
	8	4.19	.165	42.4	1.670	40.5	1.595	45.6	1.795	8012-2-8	M-91	R-48
	10	3.40	.134	43.9	1.732	41.6	1.640	47.1	1.857	8012-2-10	M-91	R-50
	11	3.04	.120	44.7	1.760	42.4	1.670	47.8	1.885	8012-2-11	M-91	R-52
	12	2.76	.109	45.2	1.782	43.2	1.704	48.4	1.907	8012-2-12	M-91	R-54
	13	2.41	.095	45.9	1.810	43.9	1.732	49.6	1.956	8012-2-13-18	M-91	R-56
	14	2.10	.083	46.5	1.834	43.9	1.732	49.6	1.956	8012-2-13-18	M-91	R-56
	15	1.83	.072	47.1	1.856	43.9	1.732	49.6	1.956	8012-2-13-18	M-91	R-56
	16	1.65	.065	47.4	1.870	43.9	1.732	49.6	1.956	8012-2-13-18	M-91	R-56
	17	1.47	.058	47.9	1.884	43.9	1.732	49.6	1.956	8012-2-13-18	M-91	R-56
18	1.24	.049	48.3	1.902	43.9	1.732	49.6	1.956	8012-2-13-18	M-91	R-56	
(57.15)	10	3.40	.134	50.3	1.982	48.0	1.890	53.5	2.107	8012-2.1/4-10	M-92	R-56
	11	3.04	.120	51.0	2.010	48.7	1.920	54.2	2.135	8012-2.1/4-11	M-92	R-58
	12	2.76	.109	51.6	2.032	49.6	1.954	54.7	2.157	8012-2.1/4-12	M-92	R-60
	13	2.41	.095	52.3	2.060	50.3	1.982	55.4	2.185	8012-2.1/4-13-16	M-92	R-62
	14	2.10	.083	52.9	2.084	50.3	1.982	55.4	2.185	8012-2.1/4-13-16	M-92	R-62
	15	1.83	.072	53.4	2.106	50.3	1.982	55.4	2.185	8012-2.1/4-13-16	M-92	R-62
(63.50)	7-8	4.50	.177	54.5	2.146	52.0	2.050	59.3	2.335	8012-2.1/2-7-8	M-92	R-45-A
	9	3.75	.148	56.0	2.204	53.5	2.106	60.4	2.380	8012-2.1/2-9	M-93	R-46-A
	10	3.40	.134	56.6	2.232	54.3	2.140	61.1	2.407	8012-2.1/2-10-12	M-93	R-64
	11	3.04	.120	57.4	2.260	54.3	2.140	61.1	2.407	8012-2.1/2-10-12	M-93	R-64
	12	2.76	.109	57.9	2.282	54.3	2.140	61.1	2.407	8012-2.1/2-10-12	M-93	R-64
	13	2.41	.095	58.6	2.310	56.6	2.232	62.2	2.450	8012-2.1/2-13-18	M-94	R-64
	14	2.10	.083	59.2	2.334	56.6	2.232	62.2	2.450	8012-2.1/2-13-18	M-94	R-64
	15	1.83	.072	59.8	2.356	56.6	2.232	62.2	2.450	8012-2.1/2-13-18	M-94	R-64
	16	1.65	.065	60.1	2.370	56.6	2.232	62.2	2.450	8012-2.1/2-13-18	M-94	R-64
	17	1.47	.058	60.6	2.384	56.6	2.232	62.2	2.450	8012-2.1/2-13-18	M-94	R-64
18	1.24	.049	61.0	2.402	56.6	2.232	62.2	2.450	8012-2.1/2-13-18	M-94	R-64	

Model 8012-1.3/4-8 - 8012-2.1/2-13-18 expanders come with 3/4" square mandrel drives. Model 8012-2.3/4-10-16 - 8012-5-10-18 expanders come with 1" square mandrel drives.

8012 SERIES

1 3/4" - 5"
O.D.

www.tubeexengg.com

Tube O.D. (mm) inch	Tube Thickness			Tube I.D.		Minimum I.D. Tool Enters		Maximum Expansion of Tool		EXPANDER with (57.15 mm) 2.1/4" Long Rollers		
	bwg	mm	inch	mm	inch	mm	inch	mm	inch	Complete Tool No.	Mandrel No.	Rollers Set. No.
(69.85) 2.3/4	10	3.40	.134	63.0	2.482	60.7	2.390	68.6	2.702	8012-2.3/4-10-16	M-96	R-66
	11	3.04	.120	63.7	2.510	60.7	2.390	68.6	2.702	8012-2.3/4-10-16	M-96	R-66
	12	2.76	.109	64.3	2.532	60.7	2.390	68.6	2.702	8012-2.3/4-10-16	M-96	R-66
	13	2.41	.095	65.0	2.560	60.7	2.390	68.6	2.702	8012-2.3/4-10-16	M-96	R-66
	14	2.10	.083	65.6	2.584	60.7	2.390	68.6	2.702	8012-2.3/4-10-16	M-96	R-66
	15	1.83	.072	66.1	2.606	60.7	2.390	68.6	2.702	8012-2.3/4-10-16	M-96	R-66
	16	1.65	.065	66.5	2.620	60.7	2.390	68.6	2.702	8012-2.3/4-10-16	M-96	R-66
(76.20) 3	8	4.19	.165	67.8	2.670	65.0	2.560	71.8	2.829	8012-3-8-9	M-97	R-67
	9	3.75	.148	68.6	2.704	65.0	2.560	71.8	2.829	8012-3-8-9	M-97	R-67
	10	3.40	.134	69.3	2.732	67.0	2.640	74.9	2.952	8012-3-10-18	M-96	R-67
	11	3.04	.120	70.1	2.760	67.0	2.640	74.9	2.952	8012-3-10-18	M-96	R-67
	12	2.76	.109	70.6	2.782	67.0	2.640	74.9	2.952	8012-3-10-18	M-96	R-67
	13	2.41	.095	71.3	2.810	67.0	2.640	74.9	2.952	8012-3-10-18	M-96	R-67
	14	2.10	.083	71.9	2.834	67.0	2.640	74.9	2.952	8012-3-10-18	M-96	R-67
	15	1.82	.072	72.5	2.856	67.0	2.640	74.9	2.952	8012-3-10-18	M-96	R-67
	16	1.65	.065	72.8	2.870	67.0	2.640	74.9	2.952	8012-3-10-18	M-96	R-67
(88.9) 3.1/2	13	2.41	.095	84.1	3.311	81.0	3.190	88.0	3.464	8012-3.1/2-10-18	M-99	R-70
	14	2.10	.083	84.7	3.334	81.0	3.190	88.0	3.464	8012-3.1/2-10-18	M-99	R-70
	15	1.83	.072	85.2	3.354	81.0	3.190	88.0	3.464	8012-3.1/2-10-18	M-99	R-70
	16	1.65	.065	85.6	3.370	81.0	3.190	88.0	3.464	8012-3.1/2-10-18	M-99	R-70
	17	1.47	.058	86.0	3.385	81.0	3.190	88.0	3.464	8012-3.1/2-10-18	M-99	R-70
	18	1.24	.049	86.4	3.401	81.0	3.190	88.0	3.464	8012-3.1/2-10-18	M-99	R-70
(101.6) 4	3	6.60	.259	88.4	3.480	87.0	3.425	96.0	3.780	8012-4-3-4	M-100	R-71
	4	6.00	.236	89.6	3.527	87.0	3.425	96.0	3.780	8012-4-3-4	M-100	R-71
	8	4.19	.165	93.2	3.670	91.0	3.582	100.0	3.940	8012-4-8-9	M-101	R-71
	9	3.75	.148	94.1	3.704	91.0	3.582	100.0	3.940	8012-4-8-9	M-101	R-71
	10	3.40	.134	94.8	3.732	93.0	3.661	100.6	3.960	8012-4-10-18	M-101	R-72
	11	3.04	.120	95.5	3.760	93.0	3.661	100.6	3.960	8012-4-10-18	M-101	R-72
	12	2.76	.109	96.1	3.783	93.0	3.661	100.6	3.960	8012-4-10-18	M-101	R-72
	13	2.41	.095	96.8	3.811	93.0	3.661	100.6	3.960	8012-4-10-18	M-101	R-72
	14	2.10	.083	97.4	3.834	93.0	3.661	100.6	3.960	8012-4-10-18	M-101	R-72
(114.3) 4.1/2	3	6.60	.259	101.1	3.980	100.0	3.940	109.0	4.291	8012-4.1/2-3-4	M-102	R-73
	4	6.00	.236	102.3	4.030	100.0	3.940	109.0	4.291	8012-4.1/2-3-4	M-102	R-73
	8	4.19	.165	105.9	4.170	102.0	4.020	111.0	4.370	8012-4.1/2-8-9	M-102	R-74
	9	3.75	.148	106.8	4.204	102.0	4.020	111.0	4.370	8012-4.1/2-8-9	M-102	R-74
	10	3.40	.134	107.5	4.232	104.0	4.100	113.0	4.450	8012-4.1/2-10-18	M-103	R-74
	12	2.76	.109	108.8	4.283	104.0	4.100	113.0	4.450	8012-4.1/2-10-18	M-103	R-74
	16	1.65	.065	111.0	4.370	104.0	4.100	113.0	4.450	8012-4.1/2-10-18	M-103	R-74
(127.0) 5	3	6.60	.259	113.8	4.480	112.0	4.410	121.0	4.763	8012-5-3-4	M-105	R-76
	4	6.00	.236	115.0	4.527	112.0	4.410	121.0	4.763	8012-5-3-4	M-105	R-76
	8	4.19	.165	118.6	4.670	116.0	4.566	125.0	4.921	8012-5-8-9	M-105	R-77
	9	3.75	.148	119.5	4.704	116.0	4.566	125.0	4.921	8012-5-8-9	M-105	R-77
	10	3.40	.134	120.2	4.732	117.0	4.606	126.0	4.960	8012-5-10-18	M-105	R-78
	11	3.04	.120	121.0	4.763	117.0	4.606	126.0	4.960	8012-5-10-18	M-105	R-78
	12	2.76	.109	121.5	4.783	117.0	4.606	126.0	4.960	8012-5-10-18	M-105	R-78
	14	2.10	.083	122.8	4.834	117.0	4.606	126.0	4.960	8012-5-10-18	M-105	R-78
	16	1.65	.065	123.7	4.870	117.0	4.606	126.0	4.960	8012-5-10-18	M-105	R-78

Model 8012-1.3/4-8 - 8012-2.1/2-13-18 expanders come with 3/4" square mandrel drives. Model 8012-2.3/4-10-16 - 8012-5-10-18 expanders come with 1" square mandrel drives.

TUBEEX TUBE TOOLS